

830452

**SUBWOOFER 10" XTRA-LONG-STROKE 8 ohm**

**308 SWR 51 147 NX ALP 4L XLS 8/5 ohm XTRA-LONG-STROKE**

By introducing the new range of Xtra Long Stroke (XLS) subwoofers, Peerless has pushed the performance limits for subwoofers to a new level. The XLS/subwoofer range will fulfil every demand for deep clean bass reproduction like active THX home theater and Dolby Digital subwoofer applications. In the design, the emphasis has been put in achieving extreme deep bass, long time reliability, high power handling, and very low distortion - even under very large sound pressures. The 10" XLS is suitable for several different cabinet configurations, from small passive radiator assisted subwoofers to classical and car applications. This is a new range from Peerless to suit the unlimited demands of bass hungry enthusiasts in home or automotive audio. Double magnet. Cast iron frame. Large rubber surround. Gold binding posts.

Parameters:

Nominal impedance	Zn	(ohm)	
Minimum impedance/at freq.	Zmin	(ohm/Hz)	
Maximum impedance	Zo	(ohm)	
DC resistance	Re	(ohm)	
Voice coil inductance	Le	(mH)	
Capacitor in series with 8 ohm (for impedance compensation)	Cc	(µF)	
Resonance Frequency	fs	(Hz)	
Mechanical Q factor	Qms		
Electrical Q factor	Qes		
Total Q factor	Qts		
F (Ratio fs/Qts)	F	(Hz)	
Mechanical resistance	Rms	(Kg/s)	
Moving mass	Mms	(g)	
Suspension compliance	Cms	(mm/N)	
Effective cone diameter	D	(cm)	
Effective piston area	Sd	(cm <sup>2</sup> )	
Equivalent volume	VAS	(ltrs)	
Force factor	Bl	(N/A)	
Reference voltage sensitivity			
Re 2.83V 1m at 115 Hz (Measured)		(dB)	88.4
Voice coil diameter	d	(mm)	51
Voice coil length	h	(mm)	33
Voice coil layers	n		4
Flux density in gap	B	(T)	1.04
Total useful flux		(mWb)	2.50
Height of the gap	hg	(mm)	8
Diameter of magnet	dm	(mm)	147
Height of magnet	hm	(mm)	35
Weight of magnet		(kg)	2.42
Code			830452

	Free air	Common	Baffled
Nominal impedance		8	
Minimum impedance/at freq.		4.9/115	
Maximum impedance		53.3	
DC resistance		3.4	
Voice coil inductance		4.3	
Capacitor in series with 8 ohm (for impedance compensation)		22	
Resonance Frequency	18.9		18.9
Mechanical Q factor	2.63		2.63
Electrical Q factor	0.18		0.18
Total Q factor	0.17		0.17
F (Ratio fs/Qts)			112
Mechanical resistance		6.12	
Moving mass	135.3		135.4
Suspension compliance		0.52	
Effective cone diameter		21.2	
Effective piston area		352	
Equivalent volume		89.7	
Force factor		17.5	

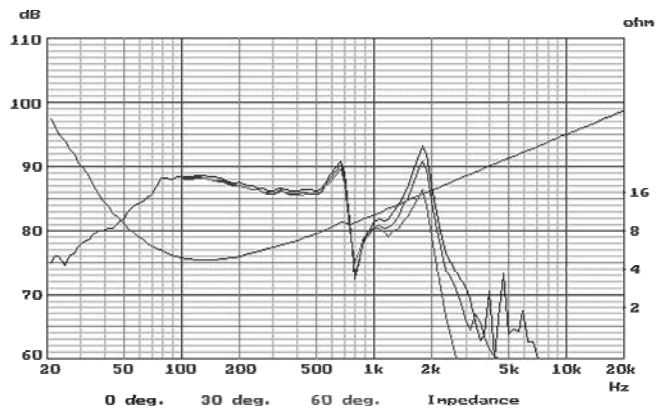
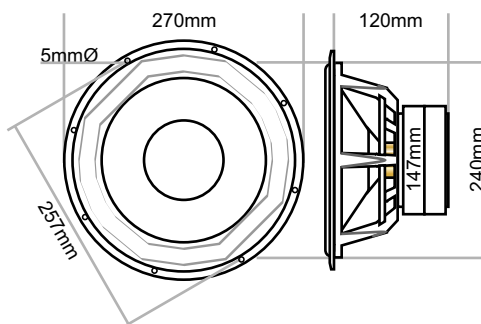



## 830452 SUBWOOFER 10" XTRA-LONG-STROKE 8 ohm

### A. Aluminum Spacer

The aluminum spacer serves as heat sink for the coil to reduce power compression.

### B. Black Anodized Voice Coil

The 2-inch 4-layer voice coil is wound on thick black anodized aluminum for improved heat dissipation.

### C. Stacked Magnet System

The twin stacked magnetic system is optimized by FEA (Finite Element Analysis), to create a symmetric powerful magnetic field in the air gap, and provide space for the 44 mm max excursion of the voice coil.

### D. Distortion Reduced Motor

A long 4 layer voice coil normally results in high self induction and impedance varying with excursion. Its many ampere turns react on the magnetic field in the air gap. These two main factors causing motor distortion in subwoofers are practically eliminated by the combined impact of the Aluminum Short Circuiting Ring (D) and the Aluminum Spacer (A) on the pole piece. At the same time they both contribute as heat sinks for the voice coil, reducing power compression. The result is unbelievable clean bass reproduction.

### E. Vented Cone

To eliminate compression under the dust cap the cone is vented by 8 large holes. This way the coil is cooled and there is no need for a bore in the pole piece.

### F. Nomex® Spider

The spider is made of high tech Nomex® material. This material is chosen for its high rigidity and long term stability. The suspension will stay in shape for a very long time under heavy load.

### G. Rubber Surround

The surround is made from SBR rubber because of the wide operating temperature, low creep and long term reliability.

### H. Fiber CompositeCone

The cone is molded from a propriety air dried wood free pulp with a blend of Nomex®, Kevlar® and glass fibers bonded together by deep impregnation with polymers. This creates an ultra stiff and relatively light cone that will stay stable even under very large sound pressures.

### I. Rigid Cast Aluminum Basket

The rigid cast basket with an aerodynamic profile provides the necessary sturdy base for the magnet structure and suspension and allows for the 44 mm max excursion of the cone. The spider is ventilated to achieve the lowest possible compression and allow air to flow freely to create a cooling effect for the voice coil.

